



BUILDING SPECIFICATIONS



A NEW CONSTRUCTION CONCEPT THAT LOOKS AT A GREENER FUTURE

MINIMUM ENERGY NEEDS

- High Thermal Efficiency Roofing
- Low consumption lighting system
- Smart Energy Consumption Control

SUSTAINABILITY

- Eco friendly construction materials
- Reuse of Rainwater
- Remote Temperature Control

INNOVATION

- Smart Home System integration
- Hybrid Photovoltaic System
- Smart Glass System



CONCRETE WORKS

Combining design with
construction solidity and
strength

STRUCTURE

Reinforcement footing and vertical structural columns anchored to the footing and foundation base. Footing and pillars calculated and sized to effortlessly bear the weight of the structure and withstand any potential stresses caused by systematic adaptations of the underlying ground.

The columns are positioned along the building's perimeter and interconnected with horizontally placed reinforced concrete beams, which work in conjunction with the pillars to form the load-bearing framework of the building itself

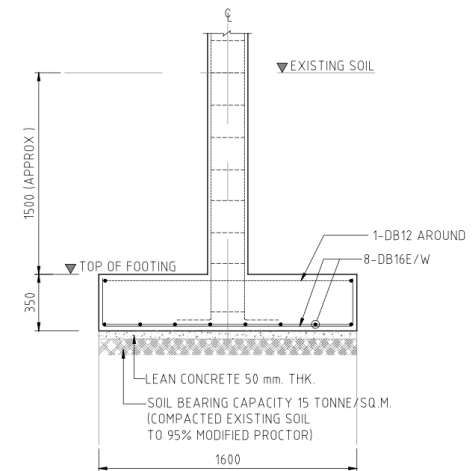
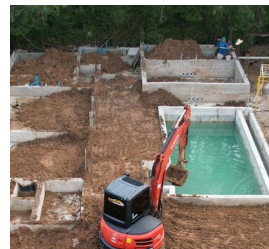



WALLS

The walls are constructed using red bricks, promoting improved ventilation, insulation, and breathability within the structure.

Red bricks helps preventing moisture from forming and also reduces the risk of mold and mildew, thus benefiting the building's longevity and overall health.

The walls are further enhanced with a skim coat plaster finish, delivering a professional, polished, and contemporary appearance that is clean-cut, even, and uniform.

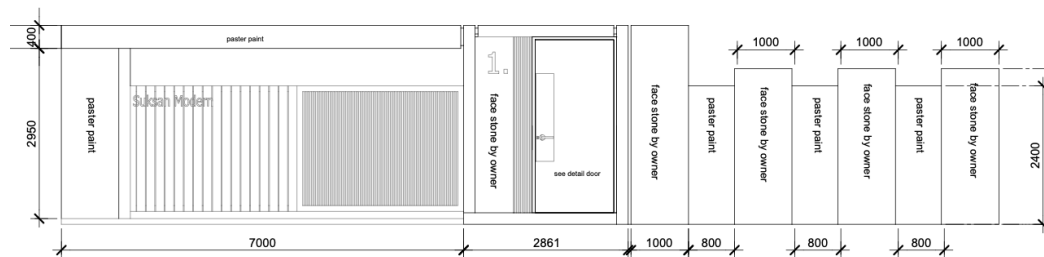

Boundary walls to be plaster finish painted, 1,8mt In height. Wall fence entrance alternating color tones and varying heights.

Each distinct earth color tone accentuates the unique character of the fence, adding depth and visual interest; the varying heights (3mt – 2,2mt) create a sense of movement and playfulness, enhancing the overall aesthetic appeal.



SWIMMING POOL

Immerse yourself in the beauty and timeless elegance of a concrete swimming pool, where relaxation and sophistication seamlessly unite in a symphony of colors and textures.

Engineered for durability and functionality, our pools are a seamless fusion of strength and style and enhancing the ambiance are two underwater spotlights, delicately illuminating the water with low-voltage 100W 12V lights.

Swimming pool is finished with customizable 4X4 inches tiles in a kaleidoscope of available colors and depth ranging from 1,40 to 1,80 meters and includes automatic chlorine filter (salt optional).

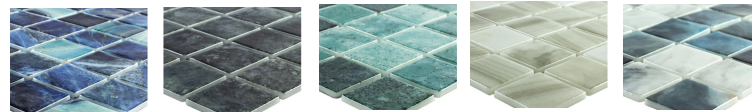



ROOFING

Reach new heights of protection and style. Explore our roofing specifications, designed to safeguard your structure while enhancing its aesthetic appeal.

ROOF AND CEILINGS



Living and Master Bedroom areas, are covered with *Canadian Shingle Roof* tiles, providing exceptional protection against storms and hurricanes while offering thermal insulation durability, and enhanced energy efficiency, translating into reduced utility costs..

Canadian Shingles are designed with the environment in mind. By incorporating up-cycled tires and plastic bags, they contribute to reducing landfill waste while increasing the shingles' strength and resilience.



Flat ceilings under concrete roofs to be 9mm plasterboard with white paint.

Vaulted ceiling covered in Teak plywood in the Master Bedroom finished with white or natural matt polyurethane

CANADIAN SHINGLE ROOF

Energy-efficient	Long-lasting	Durable
Weather-resistant	Fire-resistant	Lightweight
Low maintenance	Improved insulation	Environment friendly
Reduced cooling costs	Noise reduction	Resistant to pests and rot
Resistant to mold and mildew	30 years guarantee	Enhanced structural integrity
Resilient against extreme	Reduced risk of leaks or water damage	Recyclable material

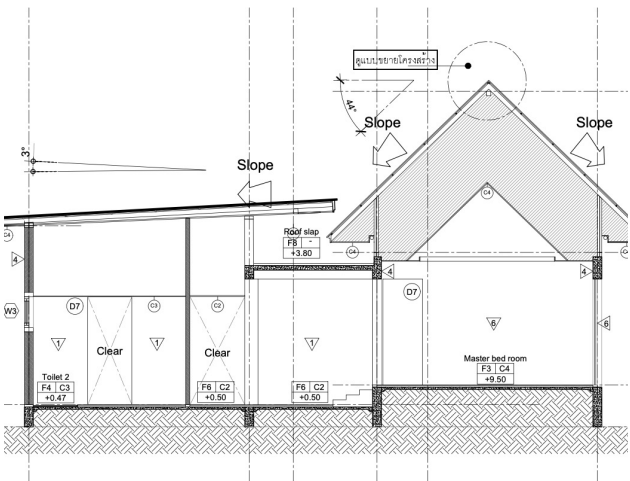

DOORS & WINDOWS

Opening pathways to elegance and quality. Discover our exceptional range of doors and windows, designed to elevate your spaces with style and durability.



DOORS

We understand that your home is a reflection of your individuality and personal taste. That's why we offer a range of options that cater to various preferences and design sensibilities. Whether you aim for a contemporary look or a more traditional ambiance, our doors provide the means to create a space that truly feels like home.

We believe in the freedom to express your unique style while preserving the timeless elegance of the past.

Our doors feature clean and easy lines, allowing you to effortlessly integrate them into any interior design scheme.

Whether you prefer the simplicity of pure wood or the added dimension of veneers, our doors come in a variety of finishes that complement any aesthetic.



DYONISUS COLLECTION

We elevate your space with the versatility of our laminate doors.

Offering a wide array of colors and designs in our standard configuration, these doors embody durability, making them an ideal choice for both short and long-term rental properties.

Experience the perfect blend of timeless beauty and functionality with our DYONISUS collection.

These doors feature clean lines, making them adaptable to modern and classic home environments, adding a touch of understated elegance to any room they grace.

Indulge in your favorite color to create a space that is visually perfect yet built to withstand the test of time. Choose laminate doors for enduring aesthetics and practicality.

WOOD COLLECTION

Upgrading to wood doors offers several distinct advantages compared to laminate doors.

While laminate doors can mimic the appearance of wood grain, nothing quite matches the authenticity and natural beauty of real wood.

Wood doors have a warm and inviting look that adds character and elegance to any space.

The natural variations in wood grain patterns and colours also make each wood door unique and one-of-a-kind.

This feature enables personalized customization options, offering the flexibility to decide a specific pattern, insert glass panels, apply custom stains or paint the door according to individual design preferences

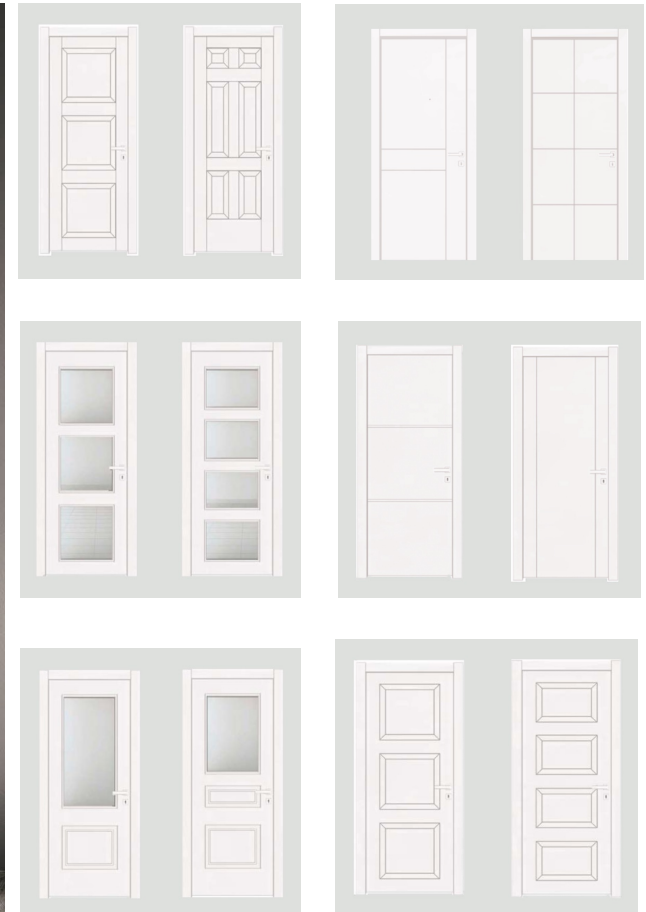

Art. 246V1
laccato bianco
white lacquered

Art. 248V3
laccato bianco
white lacquered

Art. 249V1
laccato bianco 0
white lacquered

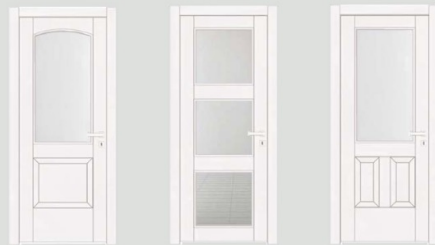

Art. 444V1
laccato bianco
white lacquered

Art. 445V1
laccato bianco
white lacquered



Art. 250V1
laccato bianco
white lacquered

Art. 251V1
laccato bianco
white lacquered

Art. 271V1
laccato bianco
white lacquered

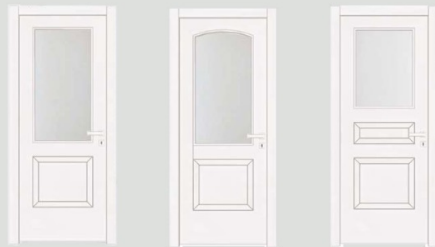

Art. 530V1
laccato bianco
white lacquered

Art. 550V1
laccato bianco
white lacquered

Art. 571V1
laccato bianco
white lacquered



Art. 283V3
laccato bianco
white lacquered

Art. 284V4
laccato bianco
white lacquered

Art. 376V1
laccato bianco
white lacquered

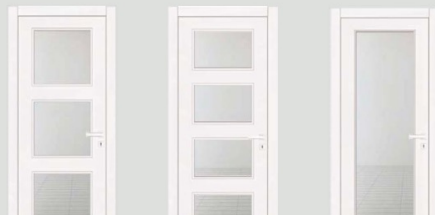

Art. 583V3
laccato bianco
white lacquered

Art. 584V4
laccato bianco
white lacquered

Art. 35V1
laccato bianco
white lacquered



Art. 394
laccato bianco
white lacquered

Art. 396
laccato bianco
white lacquered

Art. 441
laccato bianco 0
white lacquered



Art. 583
laccato bianco
white lacquered

Art. 584
laccato bianco
white lacquered

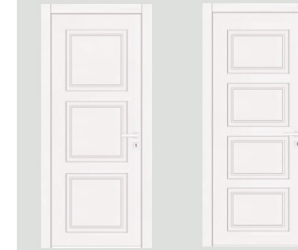

Art. 444
laccato bianco
white lacquered

Art. 445
laccato bianco
white lacquered

Art. 448
laccato bianco
white lacquered



Art. 230V1
laccato bianco
white lacquered

Art. 232V1
laccato bianco
white lacquered

Art. 241V1
laccato bianco
white lacquered



Art. 530
laccato bianco
white lacquered

Art. 550
laccato bianco
white lacquered

Art. 571
laccato bianco
white lacquered



Art. 242V1
laccato bianco
white lacquered

Art. 244V1
laccato bianco
white lacquered

Art. 245V1
laccato bianco
white lacquered

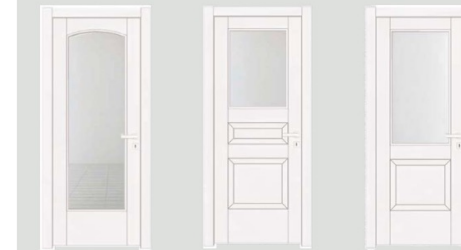

COLOR OPTIONS

Whether you prefer laminate or wood, we offer a wide range of customizable options for your doors. You have the freedom to choose from an exquisite array of colours, including walnut, oak, ash, ice oak, and tobacco, to personalize your door to your liking.

To further enhance the aesthetic appeal of your living space, our talented designers are available to provide expert guidance.

They can assist you in selecting the most complementary floor tiling colours that seamlessly blend with your chosen door finish. This ensures a harmonious and visually stunning result.



walnut



oak



ash

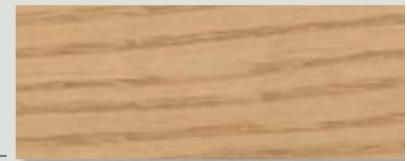

ice oak



tobacco





WINDOWS

Folding and sliding aluminium windows designed to provide efficient noise reduction, ensuring a peaceful and quiet indoor environment. The airtightness performance of aluminium windows helps to prevent drafts, maintaining optimal temperature control and energy efficiency.

All windows come with a multi-point lock system, offering enhanced security by distributing locking points across the frame, making it difficult for intruders to break in.

COLOR OPTIONS

319/2823 MIDNIGHT BLACK	29U/6090 BROWN SAHARA	380/2825 INFINITY WHITE	218/2424 SILVER SHM
302/2831 GRAY SAHARA	339/2830 DARK BROWN	304/2502 CONCRETE SAHARA	305/2822 GREYISH SAND

OPTIONAL

Aluminium windows offer a wide range of colour options and can be customized with powder coated finishing, allowing homeowners to match their aesthetic preferences.

Additionally, a smart lock can be installed in the main window entrance, providing convenient and secure access.

To keep insects out, retractable mosquito nets can be incorporated into the window design.

Lastly, for added convenience and comfort, a smart glass system can be integrated, allowing users to control the tint and transparency of the glass with ease. Aluminium windows offer a plethora of features that cater to the needs and desires of modern homeowners.

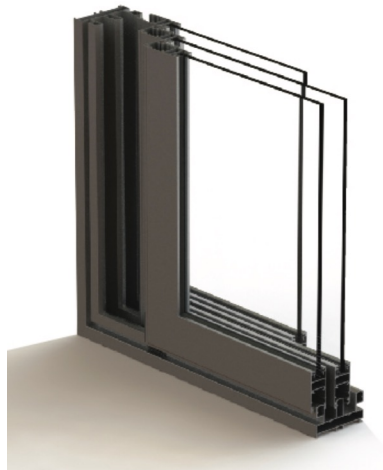
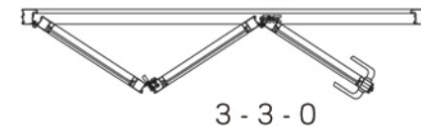
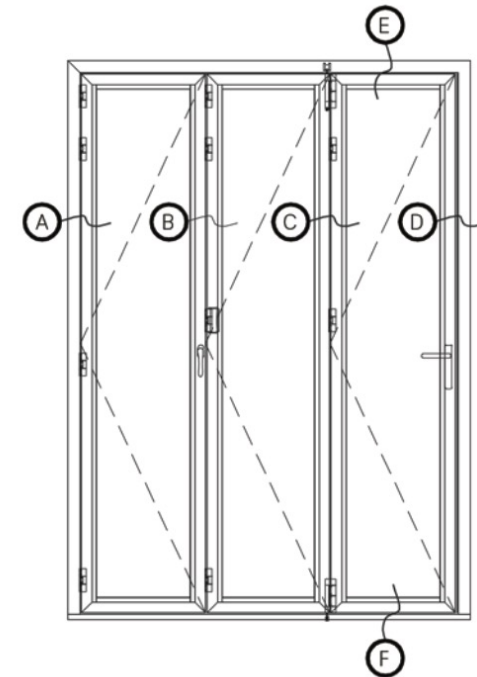

Air Tightness Performance



Noise Reduction



Wider Opening with Multi-sliding Windows System



New Angle - New Elegant

SMART GLASS SYSTEM

The smart glass system provides convenient control over window transparency and tint. When powered off, the smart film turns opaque milky white, ensuring privacy.

When powered on, the film becomes colourless and transparent, allowing light to pass through, reducing glare, and maximizing energy efficiency.

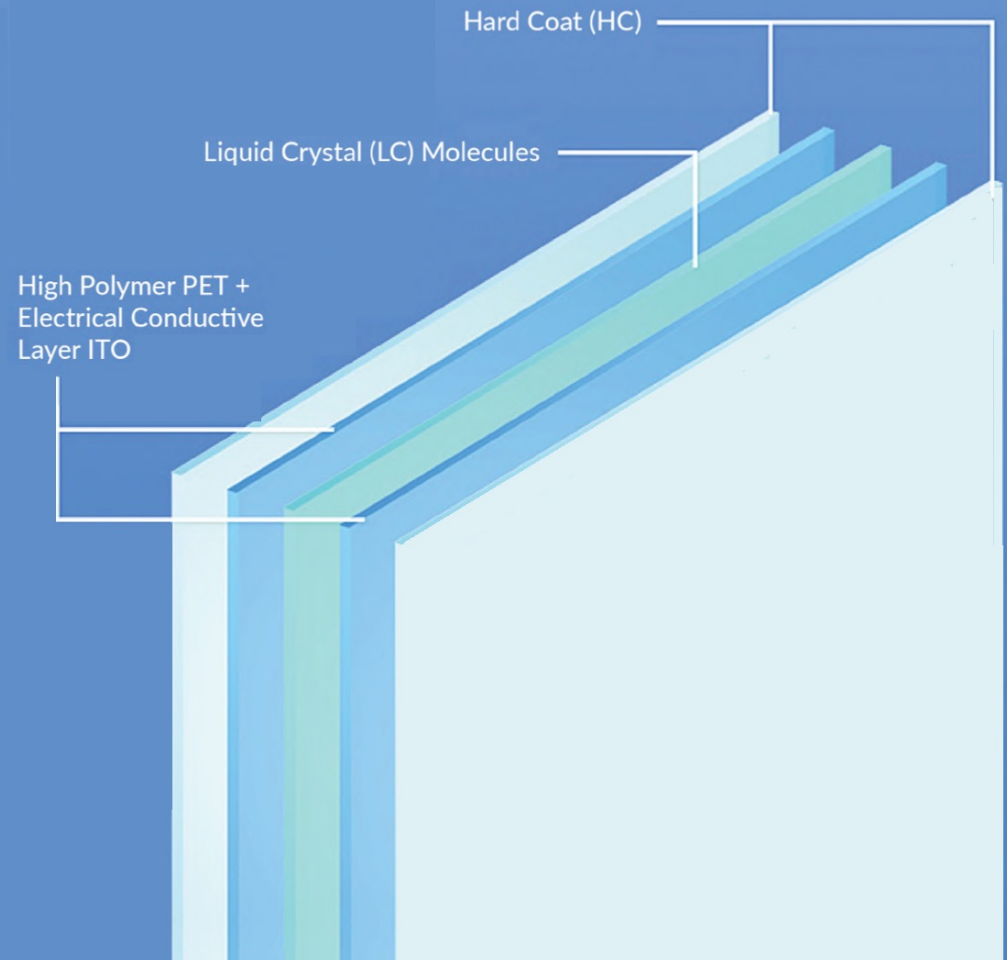

Privacy Partition	Interactive Projection	Noise Reduction	Heat Reduction	Safe Explosion Proof

DETAILS

- The Smart Film, laminated onto glass, arranges liquid crystal molecules with a low-voltage current, making the glass transparent when powered on. When powered off, the molecules randomize, causing the glass to become opaque.
- This energy-saving material can reject up to 70% of solar energy while transmitting light without heat, making it ideal for green buildings.
- The glass can serve as a multimedia display window, allowing users to switch between creative materials, transparent display, and TV screen modes.
- The combination of the "Smart Film" and glass creates a versatile material that offers intelligence, energy efficiency, privacy control, display applications, and security.
- For safety and security, the system operates on ordinary AC voltage (220VAC/110VAC) and consumes minimal power (<5 watts per square meter).

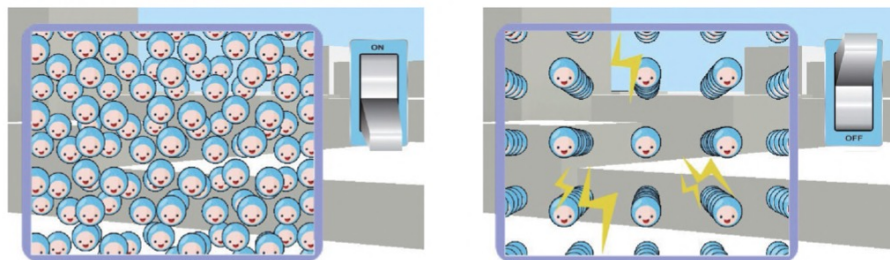

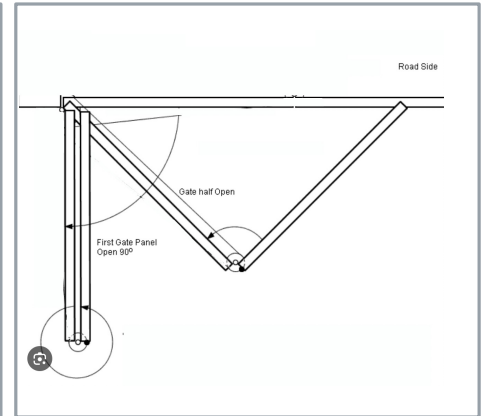
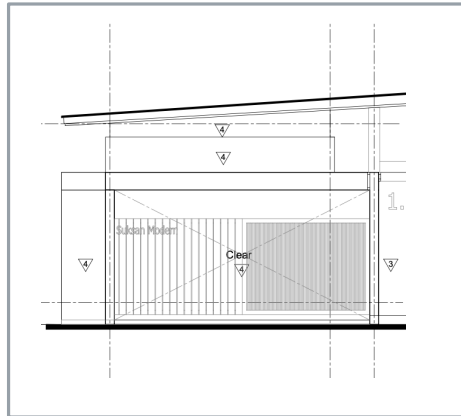

OUTDOOR GATE

Outdoor Gate System is designed to meet the demanding specifications of tropical-modern design, constructed with Conwood™ panels and metal frame. The gate system features a folding mechanism, ensuring effortless operation and smooth transitions.

It is driven by an efficient motor, delivering reliable and consistent performance. With automatic functionality, the gate effortlessly opens and closes, providing utmost convenience to the user.

The gate system is remotely controlled with two programmable remote keys for ease of access and management. Additionally, you can rely on the integrated motion sensor protection, ensuring enhanced security for your outdoor space.

A close-up photograph of a person's bare feet standing on a light-colored wood-grain floor. The person is wearing blue denim jeans with the cuffs rolled up, showing a gold-colored metal fastener. The lighting is soft and natural, highlighting the texture of the skin and the wood grain.

FLOORS & WALL TILES

The perfect flooring and tile solutions to transform your space. From versatile tiles, to elegant hardwood let your design aspirations come to life



TILES

Our catalogue offers a selection of premium materials. Whether you're looking for timeless classics or modern trends, our range of shapes, sizes, colours, and finishes ensures that you'll find the perfect tiles to transform your vision into reality.

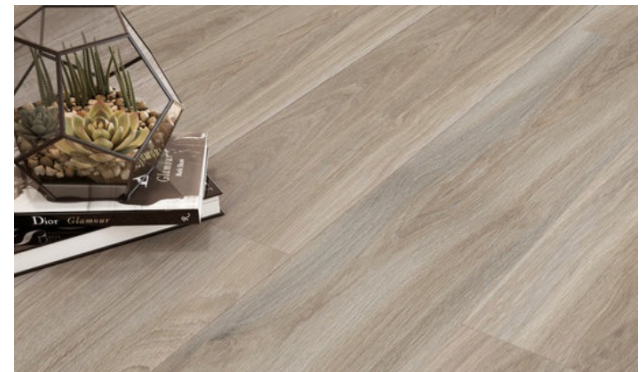

GLAZED PORCELAIN
20x120 cm. (8"x48") R/T



OMBRE SERIES
 SEPIA
 CLASSIC OAK

SURFACE : NATURAL



GLAZED PORCELAIN
20x120 cm. (8"x48") R/T



SURFACE : MATT

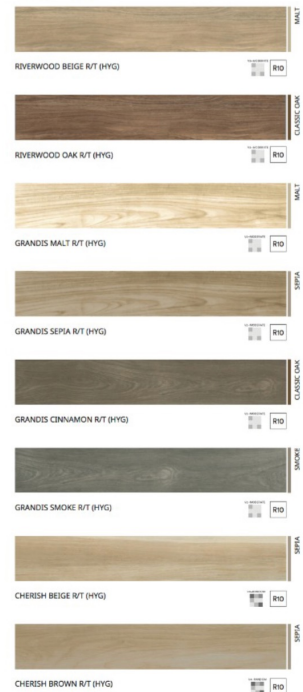

GLAZED PORCELAIN WOOD LOOK

Glazed porcelain wood look tiles offer the perfect combination of timeless elegance and incredible durability. These tiles mimic the natural beauty of wood while providing the low maintenance and longevity of porcelain.

With a wide selection of colours available, you can find the perfect glazed porcelain wood look tiles to suit your design style.

Whether you prefer classic shades like oak and walnut, or contemporary choices like ash and grey, our range of colours allows you to achieve the desired aesthetic for your space.

From rich and warm tones to cool and modern hues, explore our selection to discover the perfect colour that will elevate the look and feel of your project.

20X120 cm.

POLISHED CERAMIC

Polished ceramic tiles are a sophisticated choice that adds a touch of luxury to any space.

With their sleek and reflective surface, these tiles create a visually stunning and elegant atmosphere.

Available in a variety of colors, from neutral tones to bold hues, you have the freedom to choose a polished ceramic tile that perfectly complements your design aesthetic.

Whether you prefer a classic white or a striking black, our range of polished ceramic tiles offers endless possibilities to elevate the style and sophistication of your project.

60x60 cm.

SURFACE : POLISHED



TERRENIUM
BLANCO R/T



*White Box



TERRENIUM
LIGHT GREY R/T



*White Box



TERRENIUM
MUDDY R/T



*White Box

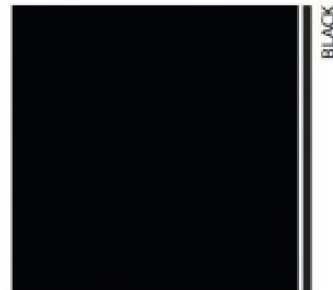

TERRENIUM NERO R/T



*White Box

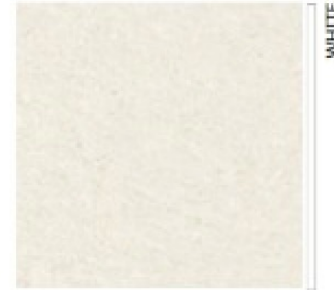

ARCHER (POL) 6611



*White Box

GLAZED PORCELAIN
30x60 cm. (12"x24") R/T



SURFACE : NATURAL



GATTO DARK GREY (IDN) (PK8) NAT R/T



GATTO LIGHT GREY (IDN) (PK8) NAT R/T

GLAZED PORCELAIN
30x60 cm. (12"x24") R/T

SURFACE : MATT



ANDES BLACK (HYG) NAT R/T



MAGMA STONE BONE (HYG) (PB) R/T



CEPPO GREI (HYG) (PB) R/T

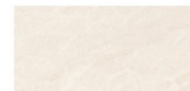

ALBA CREMA (HYG) (PB) R10 R/T

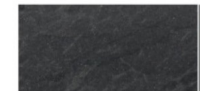

ALBA NERO (HYG) (PB) R/T



MATERA STONE BONE (HYG) R/T



SOAPSTONE BEIGE (HYG) R/T

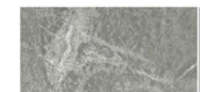

SOAPSTONE GRIGIO (HYG) R/T

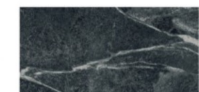

SOAPSTONE NERO (HYG) R/T



M-STONE BEIGE (HYG) R/T



M-STONE GREY (HYG) R/T

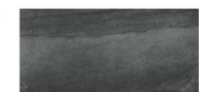

M-STONE GRAPHITE (HYG) R/T

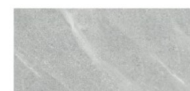

BEATSTONE LIGHT GREY (HYG) R/T

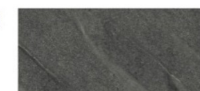

BEATSTONE COAL (HYG) R/T



NOTTING HILL GREY (HYG)



NOTTING HILL WHITE (HYG)



NOTTING HILL BEIGE (HYG)



WOOD PARQUET | OPTIONAL



WOOD PARQUET

Upgrade to wood parquet flooring for timeless beauty and a touch of natural elegance to any space. With intricate patterns and warm tones, wood parquet creates a stunning visual impact.

Choose from a variety of wood species like oak, walnut, or maple to achieve the desired aesthetic. Add character to your home or office with the classic charm and durability of wood parquet flooring.

In Thailand, a variety of wood species are used for parquet flooring, each offering unique characteristics and visual appeal.



ENERGY

Embrace the future of home automation with a smart home electric system, designed to enhance convenience, comfort, and energy efficiency.

UNDERGROUND CABLING AND INDIVIDUAL METERS

Each villa will be equipped with an easy-to-access individual meter. This will simplify the process of monitoring and managing your electricity consumption during rental activities.

In addition, all wire conduits will be carefully run underground to prevent any unsightly views of electric poles from your villa. This underground installation ensures a clean and unobstructed environment, enhancing the aesthetic appeal of your surroundings while maintaining functionality and safety.

By implementing these measures, we aim to provide a seamless and visually pleasing experience for residents, prioritizing ease of access and a clutter-free environment."



Panasonic



STANDARD

OPTIONAL

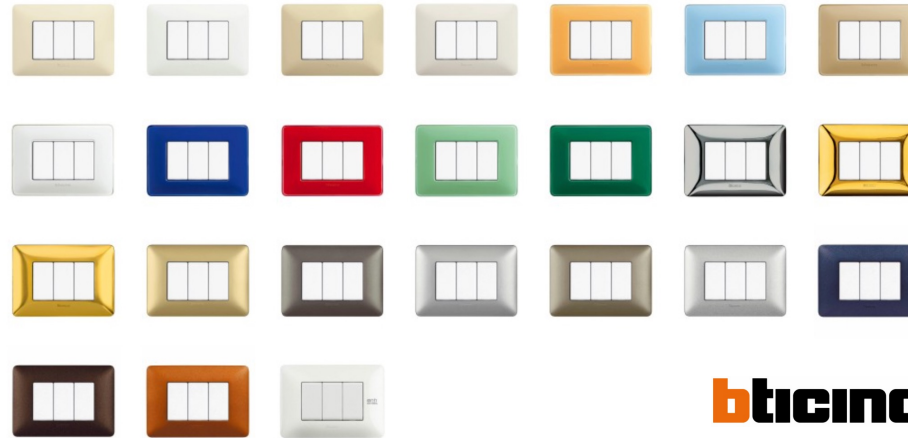

biticino

ELECTRICAL, SWITCHES, SOCKETS AND PLATES

All wiring will be concealed and run through approved PVC conduit. Earth wires will be installed and connected to all electrical outlets, as well as hardwired components, ensuring proper grounding by terminating at an approved earth spike. For convenience and functionality, we offer a standard configuration that includes Panasonic switch plates, switches, pin sockets, as well as TV and phone sockets in bedrooms and living room areas. Additionally, waterproof shaver-supply units will be installed in the bathrooms and outdoor areas, ensuring safe use of electrical equipment.

If you're interested in upgrading your electrical equipment, we recommend considering the Matix series by Biticino. This series features stylish color plates, allowing you to further enhance the aesthetic appeal of your space while maintaining high-quality functionality."



LIGHTING

To promote energy efficiency, we have incorporated low-consumption LED downlights in the living area, bedrooms, and bathrooms of each villa. These LED lights not only provide ample illumination but also help reduce energy consumption, contributing to cost savings and environmental sustainability.

In the master bedroom and master bathroom, LED strips are hidden in the gap of the gypsum ceiling. Additional LED strips are strategically inserted into the outdoor soffit gaps. These well-placed LED strips not only provide functional lighting but also add a touch of enchantment, immersing your outdoor space in a great atmosphere

To enhance the ambiance of outdoor areas, we install garden lights and lanterns around the garden and swimming pool.

With these lighting features, we aim to provide a visually pleasing environment that balances aesthetics, energy efficiency, and functionality in your villa, both indoors and outdoors



By incorporating these outdoor LED strips, we aim to create a visually stunning environment that will elevate your outdoor experience. Whether enjoying a quiet evening or hosting gatherings, these LED strips will surely contribute to an unforgettable atmosphere, making your outdoor space truly special.

LED STRIPES



LED LANTERNS

We illuminate your swimming pool area with mesmerizing LED lanterns, creating a captivating ambiance amidst the lush tropical vegetation.



German Invested & Engineered

Mars M5

EL-530~550M5-72H

PERC Technology

Mono Crystalline PV Modules



PHOTOVOLTAIC SYSTEM

By generating electricity from sunlight, photovoltaic systems can significantly reduce or even eliminate your dependency on traditional electricity sources, resulting in lower energy bills over time.

Photovoltaic systems harness the power of sunlight, a virtually unlimited and renewable energy source, making it a sustainable and environmentally friendly option.

As electricity prices rise, your solar system can offset those costs, potentially saving you money in the long run.

Photovoltaic systems require minimal maintenance, as they have no moving parts. Regular cleaning of the solar panels and occasional inspections are usually sufficient to keep them operating optimally.

With a photovoltaic system, you can become less reliant on the power grid, offering increased energy independence and resilience during power outages or grid failures

144

CELLS



Micro-crack Free



PID Resistant



Salt Mist and Ammonia Corrosion Resistant



German Engineering



Tier 1 Choice of Materials

GERMAN QUALITY

East Lux solar panels are made from top grade materials, automated robotic lines, German technology and standards, making the quality difference.

PERFORMANCE& INVESTMENT GURANTEE

East Lux assures high investment, security and warranty claims by providing linear performance guarantee of 25 years and 12 years of product warranty.

Reliable Quality

- IEC61215, IEC61730(2016), IEC TS 62804-1-1:2020 (Anti PID)
- ISO 9001:2008 Quality management systems
- ISO 14001:2004 Environmental management systems
- BS OHSAS 18001: 2007 Occupational health and safety management system
- Positive power tolerance: 0~+5W
- 100% Triple EL inspection ensure free of defects



PLUS SORTING

0~+5W positive sorting system to assure high output.

STABLE& STRONG

Capable to bear heavy snow loads up to 5400pa and wind loads up to 2400pa.

Linear Performance Warranty

12 years product warranty
25 years linear power warranty

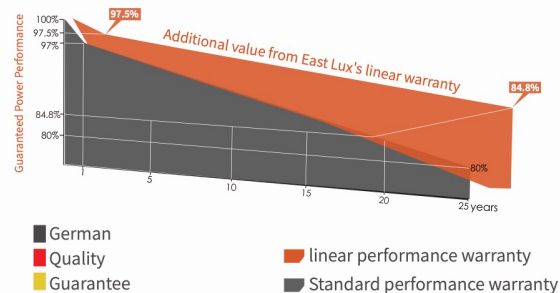

PHOTOVOLTAIC SYSTEM

Solar power is a clean energy source, emitting no greenhouse gases or pollutants during electricity generation. Opting for a photovoltaic system helps reduce your carbon footprint and contributes to mitigating climate change.

With a photovoltaic system, you can become less reliant on the power grid, offering increased energy independence and resilience during power outages or grid failures.

Our Hybrid system can be tailored to meet different energy needs and expanded based on requirements. They can be designed with appropriate battery storage capacity (optional) and solar panel arrays to match the energy demands of your home or business.

STANDARD CONFIGURATION

10,00 KWP

Villa Suksan comes equipped with a state-of-the-art **10 kWp photovoltaic system** and 18 solar panels seamlessly integrated into the sandwich metal panels roofing.

These solar panels are completely hidden and not visible from the garden, allowing you to enjoy the beautiful surroundings without any visual disruptions.

This innovative installation ensures both energy efficiency and a visually stunning architectural design. Get ready to harness clean and renewable energy while maintaining the pristine charm of your villa.

18 Solar Modules EstLux 550W MBB

1 KTL-10 Hybrid SOFAR SOLAR Inverter
3p 400V Hybrid 10kw AC EPS SYSTEM Integrate

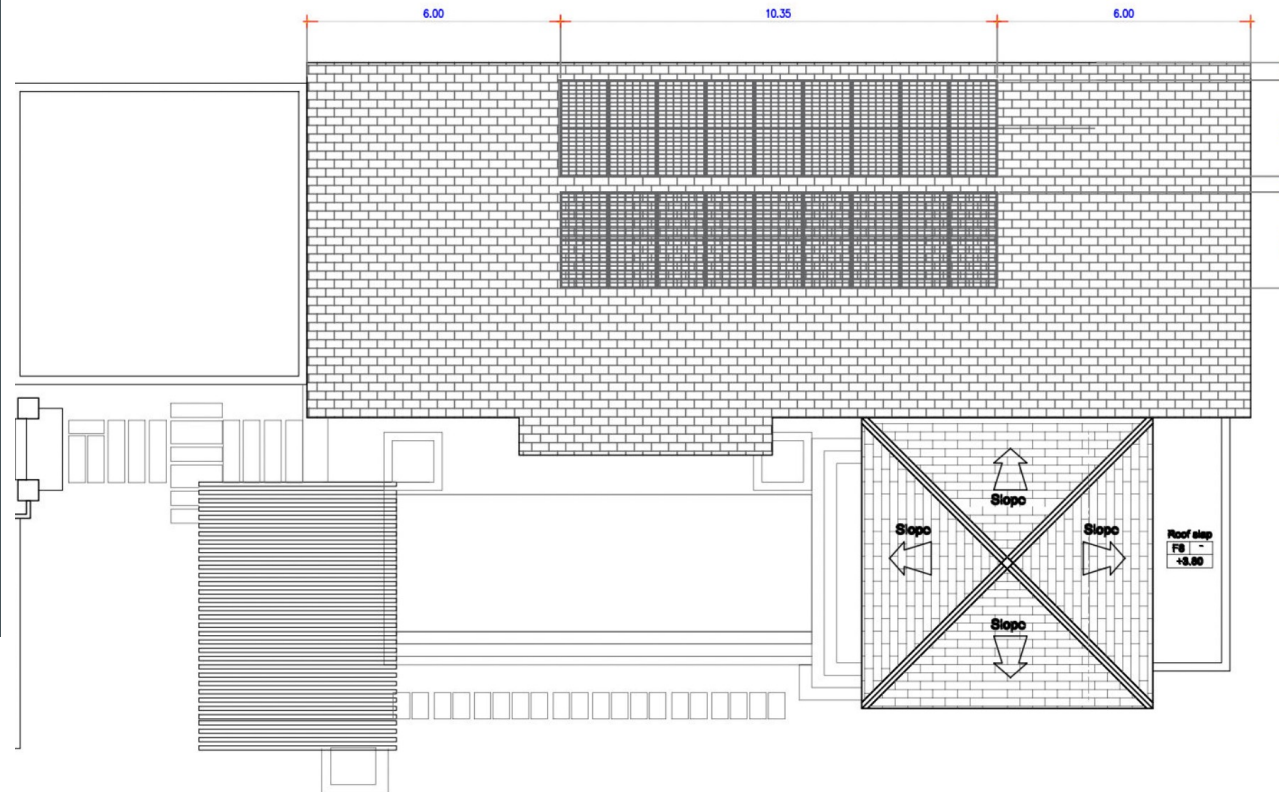

SMART HYBRID

Our photovoltaic hybrid system offers the advantage of automatically switching between grid power and solar power based on certain conditions.

By combining grid power and solar power with a battery backup, a hybrid system allows you to reduce your reliance on the grid and have power available during grid outages. This enhances your energy independence and keeps essential appliances running even when the grid is down.

A hybrid system intelligently manages energy production and consumption, automatically prioritizing solar power over grid power when available. This means that excess solar energy can be stored in the battery for later use or fed back into the grid, optimizing your energy usage and allowing to save up to 100% on electric bills.



Active Safety

AI Powered
Active Arcing Protection



Higher Yields

Up to 30% More Energy
with Optimizer



Battery Ready

Plug & Play battery interface ¹



Flexible Communication

WLAN, Fast Ethernet, 4G
Communication Supported

OPTIONAL



At Villa Suksan, excellent news is that your roof has enough space to accommodate a doubled number of panels in your photovoltaic system!

Flexibility is key when it comes to your photovoltaic system. With your setup, you have the opportunity to easily upgrade and expand as your energy needs evolve.

By adding more solar panels and a battery storage pack, you can enhance the performance and capabilities of your system saving up to 100% on electric bills.

The upgrade configuration not only allow you to increase your energy production, but it will also enable you to store excess energy for later use, maximizing your self-consumption and reducing reliance on the grid.

The option to upgrade provides you with the freedom to adapt your system to meet your changing energy requirements and make your villa even more energy-efficient and self-sustainable. Enjoy the freedom to scale up your photovoltaic system whenever you choose!

14,30 KWP

Consider upgrading your existing photovoltaic system by adding more solar panels to increase your solar supply.

By implementing an upgrade with additional 12 solar panels on your roof, you can significantly boost your solar supply and save more on your electric bill.

26 Solar Modules EstLux 550W MBB

1 KTL-10 Hybrid SOFAR SOLAR Inverter
3p 400V Hybrid 10kw AC EPS SYSTEM Integrate

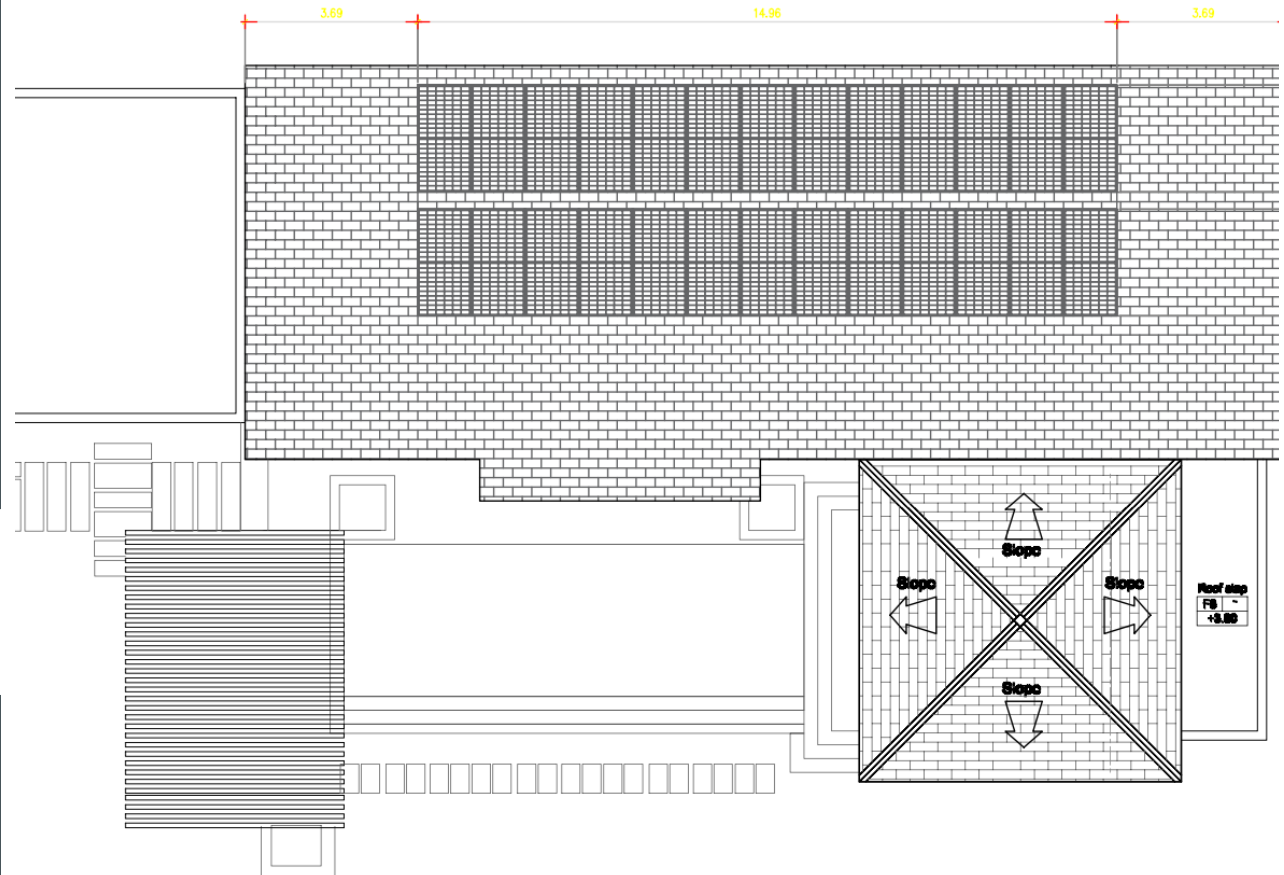

19,80 KWP

Unlock the full potential of your flat, metal roof by doubling your photovoltaic system with the addition of 18 solar panels.

With this upgrade, you can maximize your solar supply and reach a significant energy output of 19.80 kWh.

36 Solar Modules EstLux 550W MBB

1 KTL-10 Hybrid SOFAR SOLAR Inverter
 3p 400V Hybrid 10kw AC EPS SYSTEM Integrate

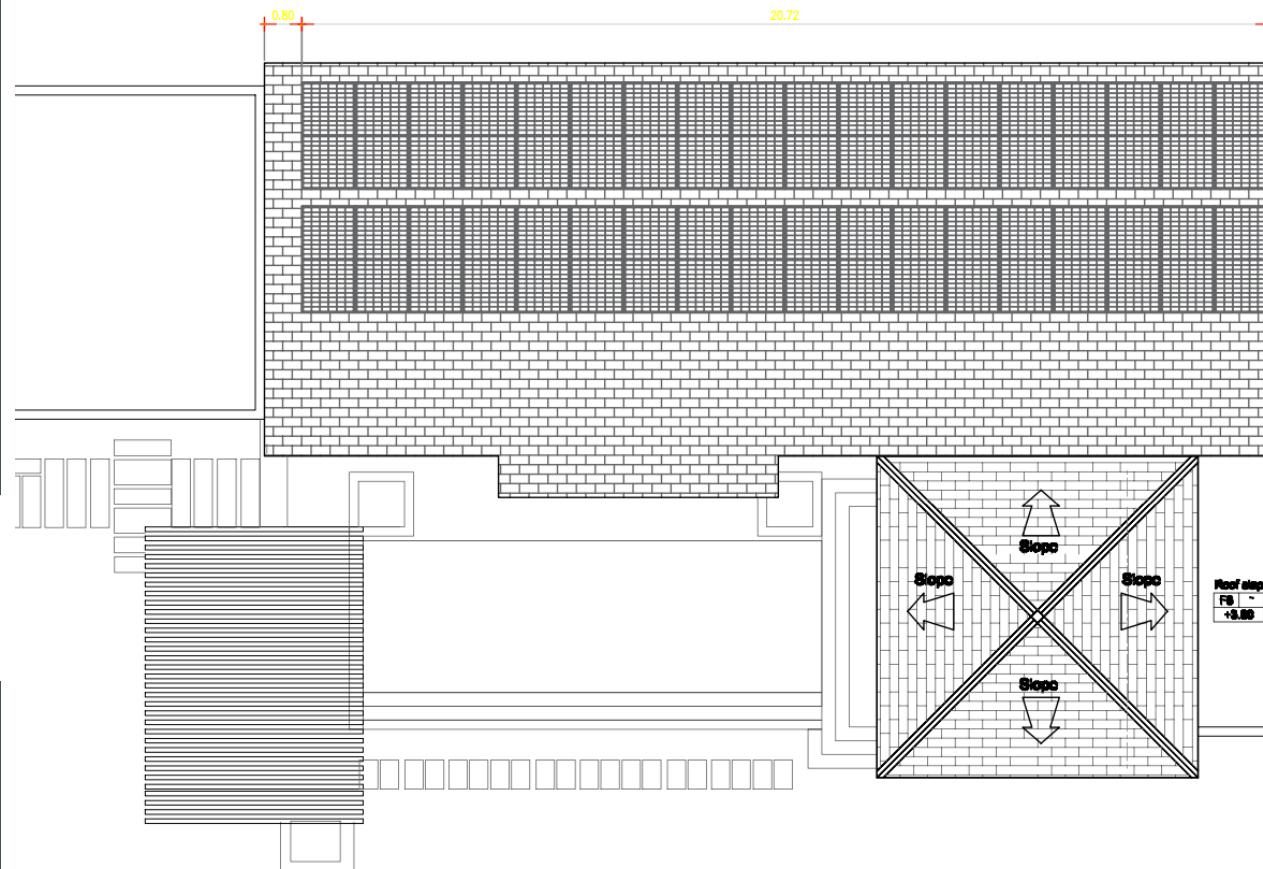

PHOTOVOLTAIC MODULE
east LUX energy EL550M5-72H

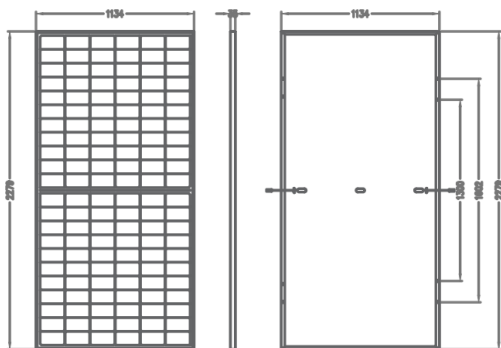

Mechanical Data
east LUX energy EL550M5-72H

Cell Type	182x91mm Mono
Cell orientation	144(6x24)
Module Dimension	2279x1134x35mm
Weight	28.5kg+-3%
Frame	Anodized aluminum alloy
Junction Box	IP68(3Bypass Diode)
Connecting Cable	300mm(+)/300mm(-)

ELECTRICAL CHARACTERISTICS

Maximum Power (Pmax/W)	550
Open Circuit Voltage (Voc/V)	49.95
Short Circuit Current (Isc/A)	14.05
Voltage at Pmax (Vmp/V)	41.97
Current at Maximum Power (Imp/A)	13.11

PROJECT DESCRIPTION
PROJECT REFERENCE

Total DC Capacity :	19.80 kWp
Total AC Capacity :	- kW
GPS Coordinates :	-
Building :	-
PV Module Brand:	east LUX energy
Modules type :	EL550M5-72H
Cell Type :	Mono crystalline
Rated Maximum Power :	550W
Strings :	-
Total PV Modules units :	36
Area solar cells :	100 sq.m.
Total Area Plot :	187 sq.m.
Smart String Inverter :	xxx
Rated AC Active Power :	xxx
Total Inverters units :	1
Mounting Structure :	BASOR
Mounting type :	xxx

MODULE SPECS

Assembled with 11BB PERC cells, the half-cell configuration of the modules offers the advantages of higher power output, better temperature-dependent performance, reduced shading effect on the energy generation, lower risk of hot spot, as well as enhanced tolerance for mechanical loading.

PV DC String Combiner Box

PV combiner box with PV disconnectors, fuses and Surge Protection Device.

IP65 DC string box is designed for multiple strings PV system. UL489B design, IEC60947-2 PV standard. Over-load, short circuit Protection. Non Polarity for easier wiring. Anti re-flux protection.

DC Cable SOLARFLEX-X H1Z2Z2-K 1500V 4mmq. Single core cables, for photovoltaic and solar system use, elastomeric compound insulated and sheathed. Flame retardant, halogen free and low smoke flexible cables for fixed laying. High resistance against Ozone, U V rays, oils, moistured and weather inclemencies Suitable for use at an ambient temperature up to 90°C (120°C overland) and tested according to: EN 50618 / TÜV Rheinland 2 PfG 1990/05.12 / TÜV R60115689

OPTIONAL



BATTERY STORAGE

Upgrading your photovoltaic system with batteries can indeed provide backup power during blackouts and enable you to utilize solar energy at night. This type of setup is typically referred to as a "solar-plus-storage" system.

With battery storage, excess solar energy generated during the day can be stored and used during power outages or during periods when the sun is not shining. This ensures that critical appliances and systems in your home or business stay powered even when the grid is down.

Adding batteries to your photovoltaic system allows you to have greater control over your energy usage. You can decide when to draw power from the grid, when to use stored solar energy, or when to sell excess energy back to the grid, maximizing your energy independence and financial benefits.



Light Control

Window Sensor

Videophone

CCTV

Smart Switches

Irrigation

Voice Control

SMART HOME

We upgrade your new home with smart solutions for a seamless, connected lifestyle

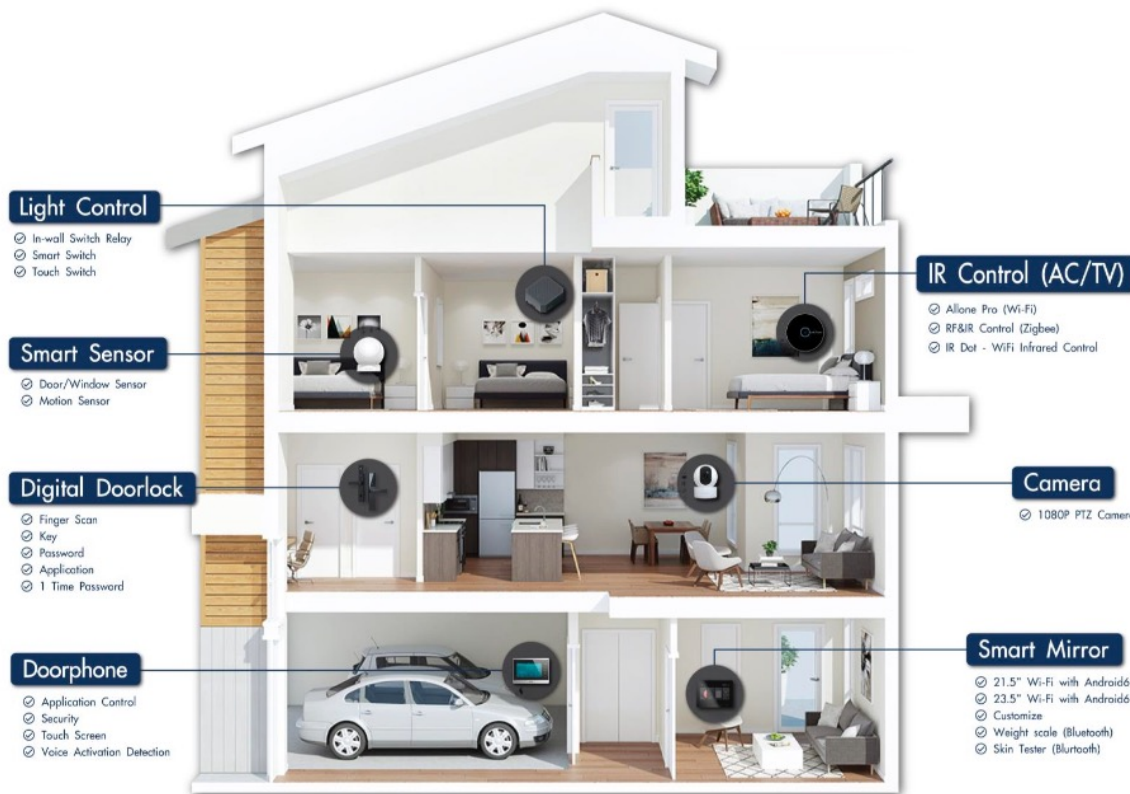

DOMOTICS SYSTEM

At Villa Suksan, efficiency meets innovation with our cutting-edge electric system, integrating smart home technology and energy-saving features for a sustainable and eco-friendly lifestyle.

Domotics, also known as home automation, is the integration of technology and automation systems within a home environment. It involves the use of smart devices and sensors to control and monitor various aspects of a household, including lighting, cooling, security, entertainment systems, and more.

With a domotic system, homeowners can control and manage different functions of their homes remotely. For example, using a smartphone app, they can easily adjust the temperature, turn on or off lights or set up automated schedules for various devices. This level of control makes daily tasks easier and more efficient, providing greater convenience and comfort.

ZIGBEE

Domotic systems also enhance home security. By integrating security cameras, motion sensors, and smart switches, homeowners and *Property Managers* can have real-time monitoring and control over the property. They can receive alerts on their smartphones in case of any suspicious activities and take immediate action, such as notifying authorities. This level of security helps to protect homes and belongings, offering peace of mind to homeowners.

Zigbee is a wireless communication protocol used for creating low-power, low-cost, and low-data-rate networks. It is designed for smart home applications, allowing devices to connect and communicate wirelessly, enabling home automation and control. Zigbee operates on the 2.4 GHz frequency band and offers a range of up to 100 meters.

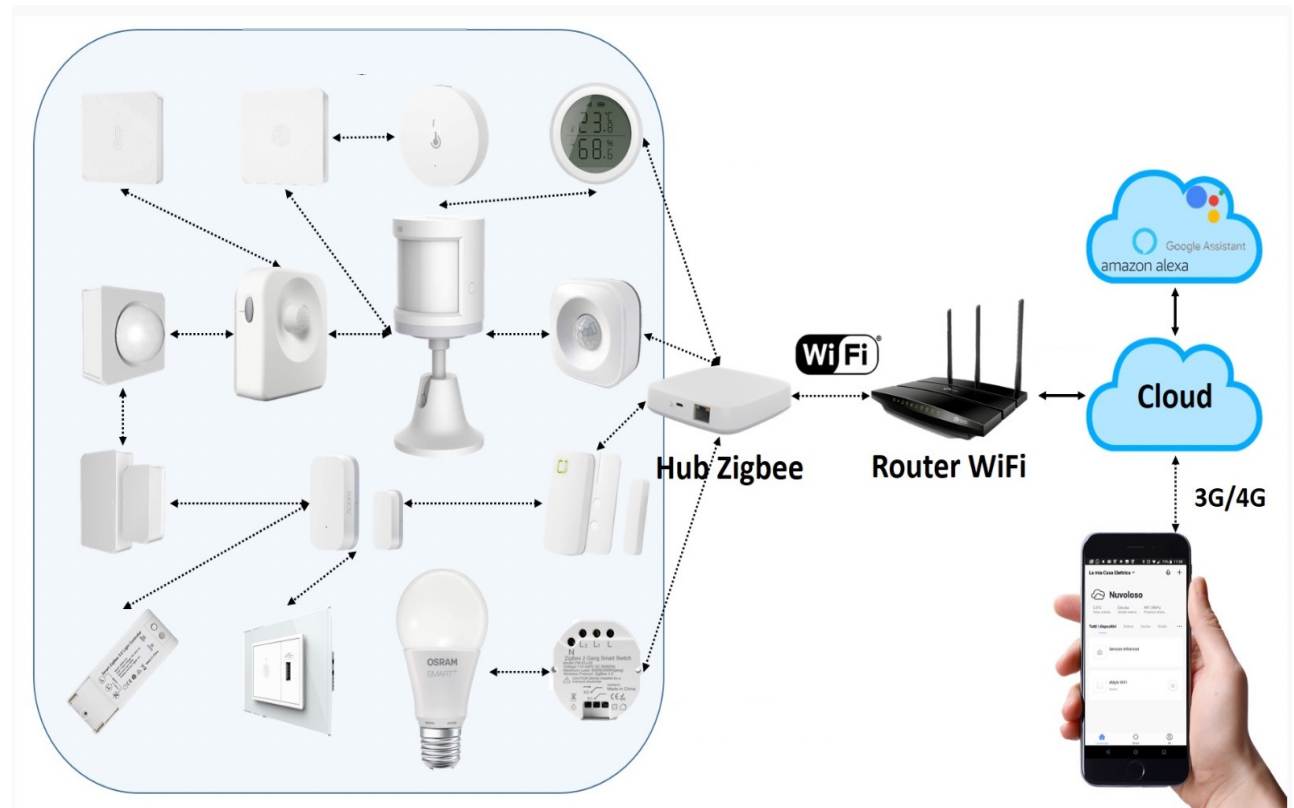

SMART CONTROL PANEL

At Villa Suksan, our Smart Home system sets new standards with its cutting-edge control panel, integrating multiple essential functions into a single, highly versatile device. This centralized hub empowers you with the convenience and control of managing various aspects of your smart home at your fingertips.

With its compact size, the Mix Pad S features a 7-inch touchscreen display that offers an intuitive interface for effortless navigation and control of all your connected smart devices. Seamlessly connect and communicate with compatible smart devices throughout your home through its built-in Wi-Fi and Bluetooth capabilities.

Not only does the Mix Pad S provide centralized control, but it also adds a touch of elegance with its sleek design. Experience the next level of smart home convenience as you effortlessly manage your lighting, temperature, security, and entertainment systems, all in one place





SMART SWITCHES

Smart switches incorporate wireless connectivity capabilities, allowing users to control their lights or devices remotely. One key feature of smart switches is their ability to be moved without the need for wires.

Smart switches are connected to Villa Suksan automation system through the wireless protocol, Zigbee. This enables users to control the switch through a smartphone app, voice commands, or even automated schedules.

With the app, users can turn lights on or off from anywhere, adjust brightness or colour temperature (if applicable), and even create custom lighting scenes.

Users can position the switch anywhere within the range of the wireless network. This flexibility allows for easy relocation and reconfiguration whenever needed, providing convenience and adaptability to changing needs.

WINDOW MOTION SENSORS

Motion sensors for windows are devices designed to detect movement or changes in motion near or around windows. These sensors are used for monitoring access and intrusions. They offer an added layer of security, effectively detecting unauthorized entry attempts.

Window motion sensors are strategically placed near windows or on window frames to detect any movement in that specific area. They can detect window breakage, glass vibration, or the movement of a person attempting to open or climb through a window.

Window motion sensors are integrated into smart home automation systems, connecting to ZigBee. This integration allows users to receive alerts and monitor their windows remotely through mobile apps, providing peace of mind even when they are away.





CCTV

CCTV system is designed for remote monitoring and offer features such as live viewing, two-way audio communication, and recording capabilities.

They have built-in speakers and microphones that allow users to not only listen but also talk through the camera remotely. This feature is particularly valuable for remote communication or surveillance scenarios. Users can interact with individuals in the camera's area, providing instructions, alerts, or deterrence if necessary.

Villa Suksan standard configuration includes two outdoor IP cameras to enhance security. It is important to consider the context in which the villa will be used.

If the villa is intended to be rented out, outdoor cameras must guarantee guests privacy but, at the same time, help deter potential intruders and assist in monitoring the premises for the safety.

VOICE CONTROL

Users can simply speak to Voice Control device to perform various tasks, such as playing music, setting reminders, checking the weather, controlling smart home devices, and accessing information.

Voice Control device analyses and processes voice commands, providing a convenient and hands-free way to interact with technology and access a range of services and features.





Wherever you are, **easily**
and securely identify visitors

You can easily check your visitors and make calls with your smartphone.



IP INTERCOM

IP videophone is a communication device that combines the functionality of a telephone with video capabilities. It allows users to make both audio and video calls over an IP network, enabling to see and communicate with the other party in real-time. They provide a more immersive and interactive communication experience, facilitating face-to-face conversations from remote locations.



AIR-CONDITIONING AND VENTILATION

Discover our cutting-edge air conditioning and ventilation section, offering superior climate control solutions to enhance your building's indoor air quality and comfort.

AIR CONDITIONING

Living Room: Experience discreet comfort with the ducted air-conditioning system gracefully concealed under the gypsum ceiling.

Bedrooms: Enjoy the perfect environment with wall-mounted split units from "Samsung" or equivalent brands. These units come with convenient remote controls, allowing you to easily adjust the temperature, change modes, activate dehumidifiers, adjust fan speed, and set auto-off functions.

Upgrade to Smart Home and connect your air conditioning systems to Wi-Fi Control, Alexa, and Google Assistant for a truly hands-free experience. Take control of your comfort with simple voice commands.

Outdoor units now utilize R32 refrigerant, ensuring higher energy efficiency compared to previous R410A models. To minimize noise pollution, the outdoor units are thoughtfully installed away from the house wall.

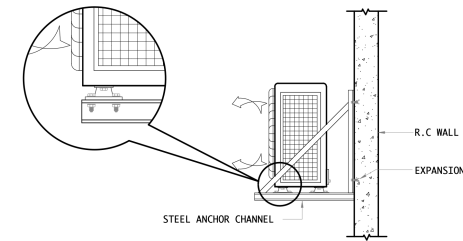

ZONE	TYPE	BTU
Living Dining area	Ducted system	24,000
Master Bedroom	Wall type split	18,000
Second Third Bedroom	Wall type split	12,000
Office Kids Room	Wall type split	9,000



FANS

EXTRACTOR FANS

CEILING FANS

Ceiling fan installed in the centre of *Master bedroom* wood ceiling enhancing the overall aesthetic and ensuring optimal air circulation and comfort.

If you're looking to upgrade other rooms and areas in your space, we offer the flexibility to install ceiling fans upon request.

EXTRACTOR FANS

Extractor fans installed in all bathrooms, triggered by the light switch when you enter the bathroom. When you leave your bathroom and turn the light out, your fan will also turn off.

Bathroom Extractor fans use very little power to operate, generally consuming between 5 - 36 watts.

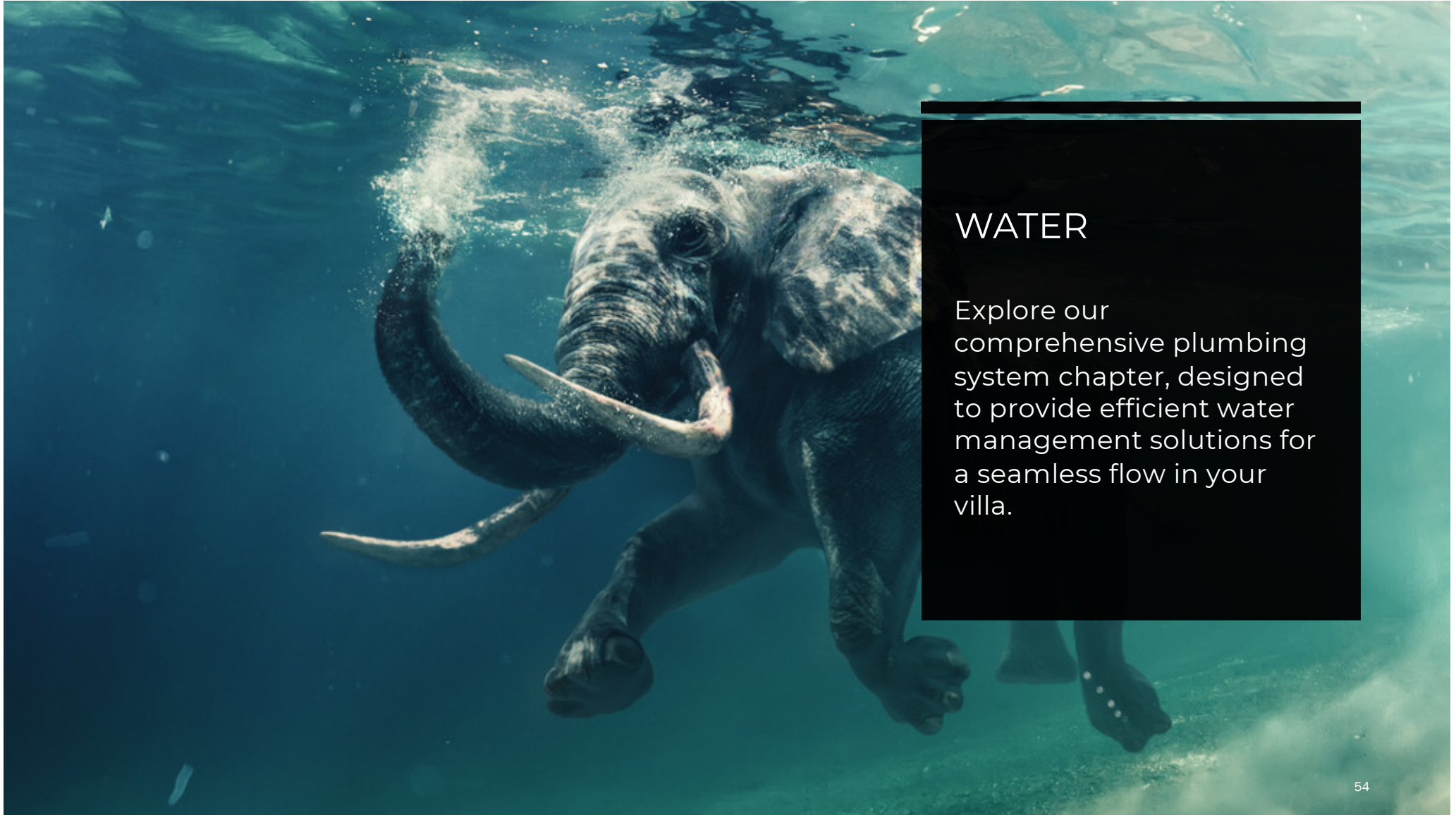

WATER

Explore our comprehensive plumbing system chapter, designed to provide efficient water management solutions for a seamless flow in your villa.



Master bathroom



Master bathroom



2nd 3rd bathroom



All bathrooms

BATHROOMS

Master Bathroom: freestanding oval bath tub in white colour, equipped with integrated water tap. Rain shower system dual control mixer. Two glass vanities and two dual control mixers.

Second / Third Bathroom: Wall mounted shower dual Control Mixer with flexible hose and hand shower with slide rail. Glass vanity and dual control mixer.

All Bathrooms: WC to be Karat, or equivalent in white colour with hand spray fitting

Exterior shower (optional) to have fixed rain shower head.



All bathrooms

IRRIGATION

Villa Suksan is equipped with rainwater collection irrigation system that has been designed to efficiently gather water from the slab roof and store it in a dedicated tank. This innovative system not only optimizes water usage but also reduces dependency on external water sources, aligning with sustainable practices.

To maximize space utilization, the water tank is cleverly nestled underneath the car parking floor. It is equipped with a booster pump to ensure adequate water pressure for irrigation purposes. What's more, this system offers the flexibility to integrate with an optional irrigation and Smart Home system.

Through Smart Home integration (optional), users can enjoy seamless control and automation of the irrigation process. With customizable settings, such as scheduling watering times and regulating water flow, the system ensures efficient distribution of water, ultimately leading to resource conservation.

By leveraging this smart technology, Villa Suksan not only delivers an exceptional level of convenience but also showcases its commitment to sustainable living by optimizing water usage and incorporating eco-friendly solutions.

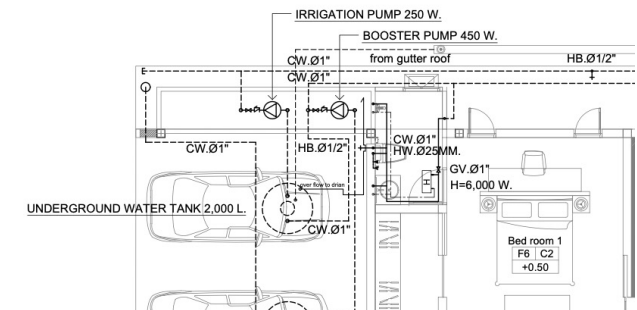

DOMESTIC SEWAGE

All grey & black water to be piped by gravity feed into 800lt septic tanks hidden behind the house for the sole use of the household unit.

The PVC material used in the construction of the tanks provides superior sealing properties, minimizing the risk of any leakage or odours.

Liquid flows out for further disposal in the underground cesspool hidden under the car parking floor.

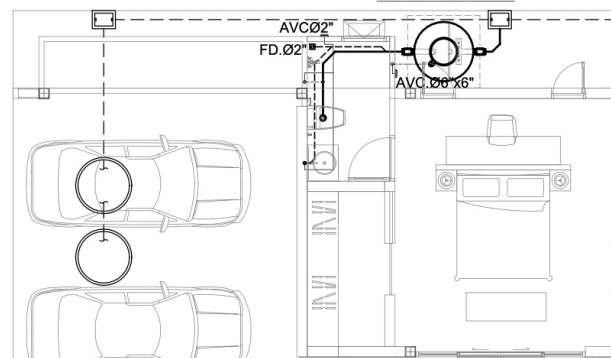
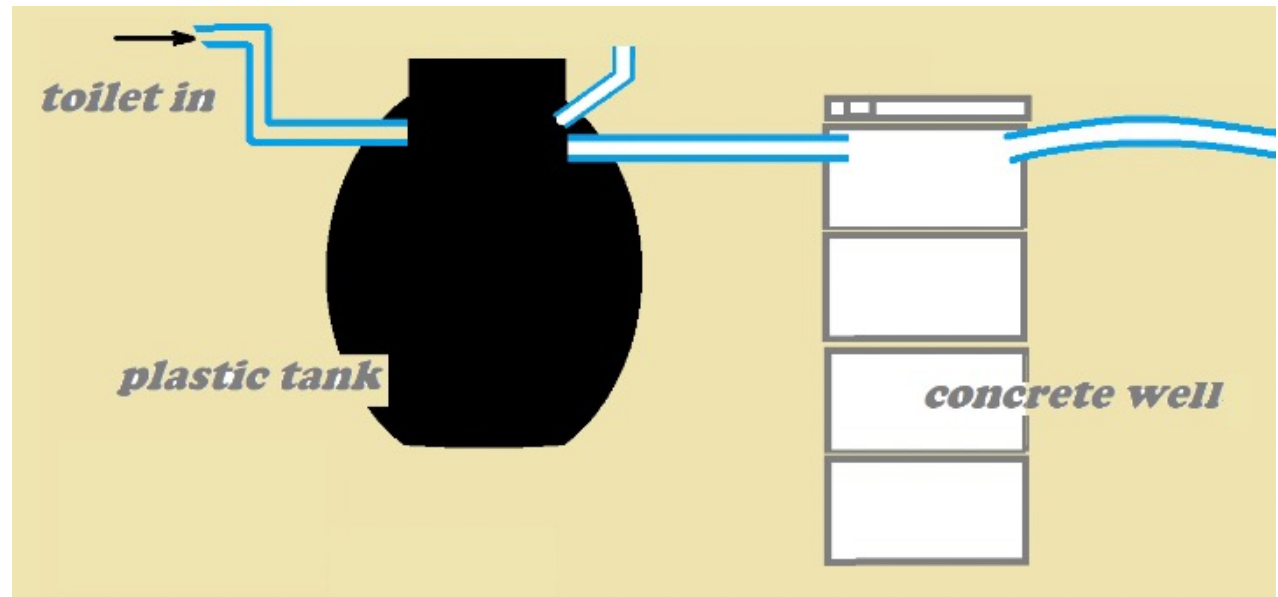

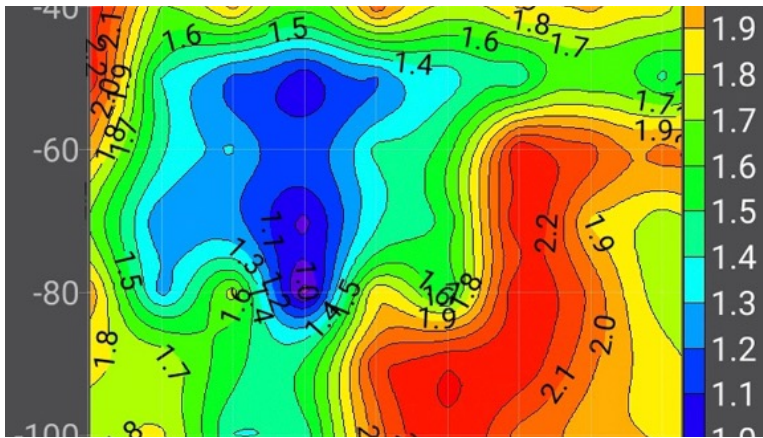

WATER SUPPLY

Water supply system sourced from a centralized artisan well water.

Water supply undergoes a comprehensive purification process utilizing carbon and sand filters.

